

Technical Data



Model	Digox 6.1 EC portable (DG 70.00.00)	Digox 6.1 EC S stationary (DG 71.00.00)
Measuring range	0...20.00 mg/l O ₂	0...20.00 mg/l O ₂
Measurement error	< 1 % related to the measured value or ± 0,005 mg/l	< 1 % related to the measured value or ± 0,005 mg/l
Resolution	0.001 mg/l	0.001 mg/l
Response time	t ₉₀ < 8 s	t ₉₀ < 8 s
Calibration	Thiedig Active Calibration with self test Calibration concentration selectable (0.200 or 0.500 mg/l O ₂) Calibration timer (reminder function), reference calibration	Thiedig Active Calibration with self test Calibration concentration selectable (0.200 or 0.500 mg/l O ₂) Periodic calibration Calibration timer (reminder function), reference calibration
Data logger	4,000 data sets in a continuous data logger storage of several measuring cycles possible	4,000 data sets in a continuous data logger storage of several measuring cycles possible
Flow	3...20 l/h, compensated automatically optimal 10 l/h	3...20 l/h, compensated automatically optimal 10 l/h
Sample pressure	maximum 8 bar, pressure peaks up to 16 bar	maximum 8 bar, pressure peaks up to 16 bar
Sample temperature	0...60 °C, automatically compensated	0...60 °C, automatically compensated (CIP up to 110 °C)
Ambient temperature	0...40 °C	0...40 °C
Signal outputs	1 x active 0(4)...20 mA freely selectable for concentration, flow, temperature 1 x switching contact (changer), freely selectable 60V/0,5A	3 x active 0(4)...20 mA freely selectable for concentration, flow, temperature 5 x switching contacts (changer), freely selectable 60V/0,5A
Interfaces	USB 2.0	USB 2.0, optional Ethernet
Power supply	12 V NiMH rechargeable battery for approx. 8 h operation Power supply plug 100...240 VAC (50/60 Hz), 20 VA	100...240 VAC (50/60 Hz), 20 VA, optional 24 VDC (DG 71.10.00)
IP Rating	IP 65	IP 65
Weight	3.8 kg	8.0 kg, mounted on stainless steel plate (optional stainless steel cabinet)
Dimensions	270 x 330 x 140 mm (H x W x D)	580 x 335 x 140 mm (H x W x D)

Subject to technical alterations.

Dr. Thiedig

Process Analysers



Dr. Thiedig GmbH & Co KG
Prinzenallee 78-79
13357 Berlin
Germany

Phone +49(0)30/49 77 69 - 0
Fax +49(0)30/49 77 69 - 25

info@thiedig.com
www.thiedig.com

Dr. Thiedig



Digox 6.1

The reference
for oxygen measurement

Digox 6.1

Accuracy where it counts

Oxygen plays a key role in quality control in the beverage industry. Monitoring the oxygen concentration during the filling process is essential, in order to comply with quality assurance requirements for better taste and a longer shelf life. The Digox 6.1 provides the highest possible accuracy and safety.



Accuracy and safety in laboratory and in process

The Digox 6.1 measures low concentrations of dissolved oxygen in beverages. Both, portable and stationary instruments are designed for continuous operation in the laboratory and in the process.

Data interfaces, analogue signals, alarms and contacts offer a variety of options to integrate the Digox 6.1 into a process control system.

The rugged design of the Thiedig sensor with its automatic calibration allows for continuous operation with a minimum of maintenance. The calibration can be performed any time during a measurement or automatically after certain periods of time. Hence, a reliable measurement is always guaranteed. The stationary Digox 6.1 can be cleaned in place at up to 110°C (230°F).

Flexible and mobile:

The Digox 6.1 EC is the portable instrument to measure low concentrations of dissolved oxygen in beverages. The rechargeable battery allows for up to 8 hours of operation. The data logger records up to 4000 data sets.

Applications Digox 6.1 EC (portable):

- As a reference to check and calibrate in-line instruments
- Measuring oxygen in cans and bottles: total package oxygen (TPO), concentration in the head space, oxygen uptake at the filler
- Detecting oxygen pick up throughout the process
- Extended stationary operation for monitoring processes

Applications Digox 6.1 EC S (stationary):

- Measuring continuously in production (e.g. downstream of the filtration or upstream of the filler) for documentation and quality assurance



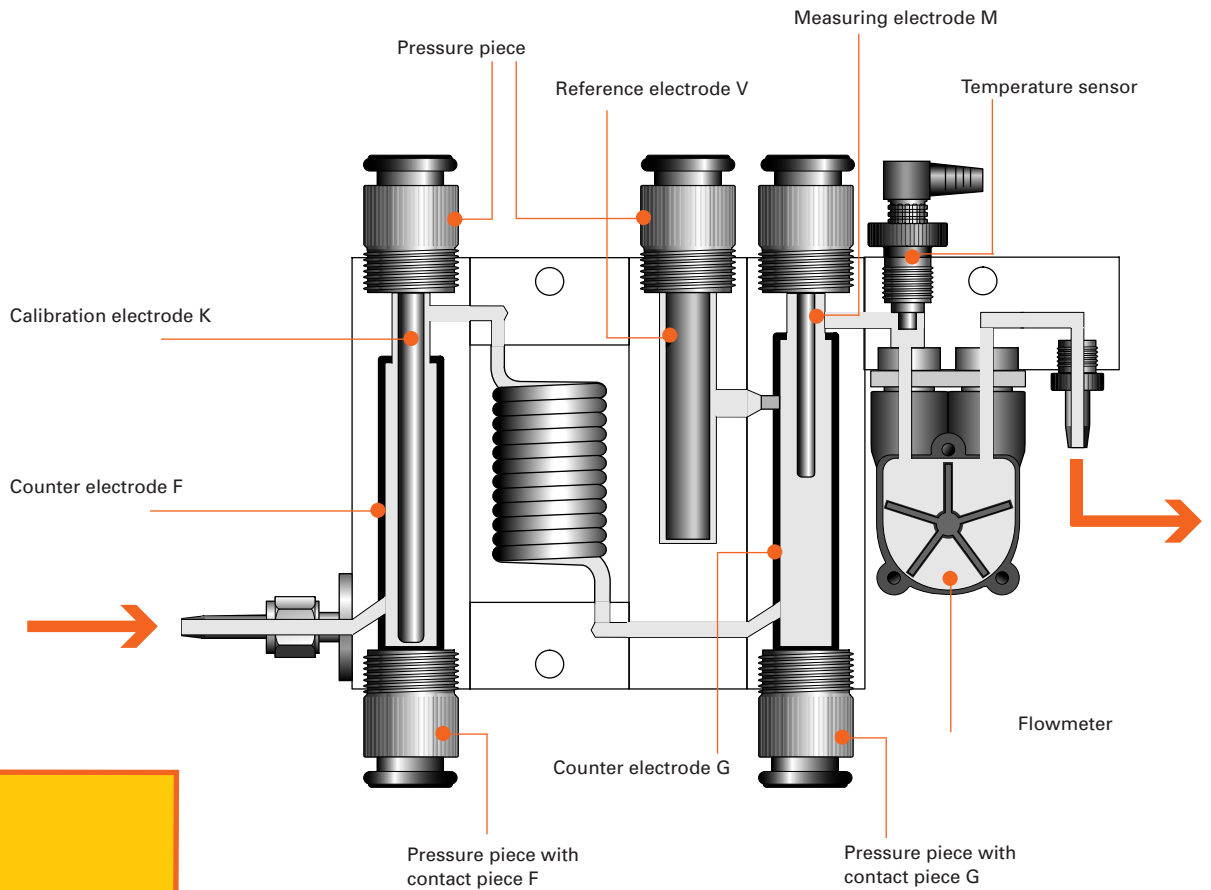

The Thiedig sensor

Reliable and rugged design

The measuring principle of the Digox 6.1 is based on the chemical reduction of dissolved oxygen on a polarized electrode. The Thiedig sensor works by means of a potentiostatically controlled arrangement of three electrodes. Unlike other measuring principles, the liquid to be analysed acts as an electrolyte and is thus not separated from the sensor by a membrane.

Advantages of the Thiedig sensor over other sensor types :

- Sensor works drift-free and reliably and can be calibrated during a measurement.
- Response time is extremely short. Small oxygen peaks can be detected.
- Rugged design allows for long maintenance intervals. Sensor can easily be cleaned.
- Sensitivity can be checked at any time without interrupting the measurement.



Accuracy at any time – The Thiedig Active Calibration

All sensors need to be calibrated, which is inconvenient and takes time. The Thiedig sensor can be calibrated during a measurement. The calibration is carried out under actual measuring conditions, and the calibration point is within the measuring range.

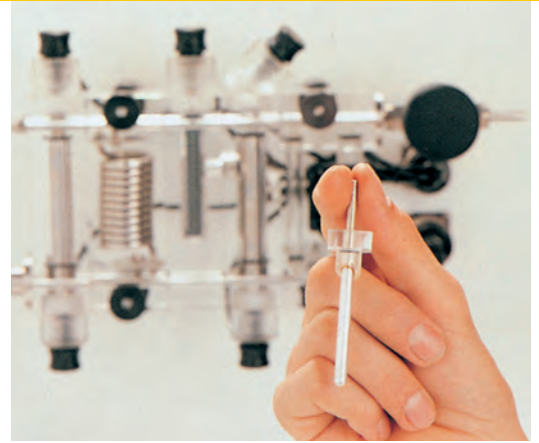

Successfully proven for decades:
the Thiedig sensor

Linear correlation
between oxygen
concentration and
calibration current

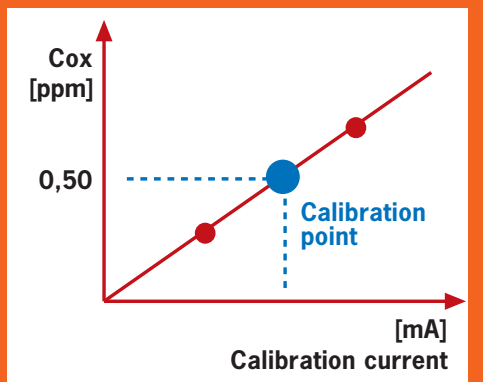

The **Thiedig Active Calibration** is based on Faraday's law and a flow measurement and therefore on two parameters that are independent of the other system parameters. A defined concentration of oxygen is generated at a certain sample flow. The sensitivity of the sensor can be checked with this calibration concentration. An error message is displayed, if there is a deviation from the required conditions. A linear correlation between oxygen concentration and measuring current is determined and extrapolated to the fixed zero point.

Advantages of the Thiedig Active Calibration

- The calibration is very accurate, works automatically and is therefore not time-consuming.
- The results can be double-checked at any time without interrupting the measurement.
- Since the calibration is carried out in the sample, any side effects can be excluded.
- All calibration data are saved and can be archived.



Digox 6.1 – Measuring the total package oxygen (TPO) in bottles and cans – easily performed

A new software feature for the Digox 6.1 provides a quick and simple measurement of the TPO in beverages.

The operator is guided through the procedure by the display of the Digox 6.1: prepare bottles, shake bottles, measure, calculate and display the results:

- Total package oxygen (TPO)
- Concentration in the head space
- Uptake at the filler

If the time for one step of the procedure is exceeded, this will be displayed and recorded. The results can be saved and evaluated with a computer.

There are different methods, which can be selected and configured according to a specific application: e.g. type of bottle, number of bottles (shaken, not shaken).



Digox 6.1 – Easy operation – at the instrument or at the computer

The menu is self-explanatory and makes operation easy. All important parameters can be displayed at once.

The data logger can save 4000 data points.



✓	0.024 mg/l	14.3°C	13:28:21
		10.0 l/h	26.05.09
Total oxygen			
Data set	16		
Date	13:27:12	26.05.09	
Location	Füller3		
Container	NRW Flasche 0,5		
Beer sort	Alkoholfrei		
Total oxygen	0.051 mg/l		

✓	0.023 mg/l	14.7°C	13:29:13
		10.0 l/h	26.05.09
Main m./Total /Show data			
Data set	(16 / 16)		
Actual user	Labor		
Method	1		
No. of Bottles (shaked)	2		
No. of Bottles (not shaked)	1		
Temperature	14.0		
Dissolved oxygen	0.024		
Control measurement	0.024		

DigoxWIN

DigoxWin is our software tool for the configuration of the Digox 6.1, firmware updates and exporting data to Microsoft Excel.

The Digox 6.1 EC S can be integrated into a process control system via Profibus-DP or Ethernet.

Digital communication with a computer is possible via USB or RS-232 (Digox 6.1 EC and EC S). In addition, analogue signals (0(4)...20 mA) are available.

